

THE BELTON IRIS SOCIETY

in cooperation with

THE AMERICAN IRIS SOCIETY

presents their

2017 IRIS SHOW

Easter Irises My Love

Saturday, April 15, 2017

7:00 a.m. – 3:00 p.m.

Doors Open:	7:00 a.m.
All Entries Deadline:	10:00 a.m.
Luncheon:	noon
Public Viewing:	1:00 – 3:00 p.m.

Saint Paul's United Methodist Church's Fellowship Hall

2407 West Avenue P

(corner of 49th Street and Avenue P)

Temple, Texas 76504-6553



The **Belton Iris Society** is an affiliate of the American Iris Society.

The **Belton Iris Society** was organized on April 18, 1951. The first show was held April 18, 1952 at the Belton Carnegie Library with 223 entries. This group is dedicated to the enjoyment and sharing of irises. Membership is extended to anyone interested in irises.

The **American Iris Society** (www.irises.org) is an international organization devoted to the promotion of the Iris. Anyone interested in this organization is invited to join today at the membership table (single, annual dues \$30) or by contacting the Membership Secretary:

Tom Gormley
P.O. Box 177
De Leon Springs, FL 32130-0177
phone and fax: (386) 277-2057
email: aismemsec@irises.org

This schedule has been submitted to and approved by:

Lois Rose
Exhibition Chair
American Iris Society
Show Registration No. 2017-092

Belton Iris Society

Current Officers 2016-2017

President Karen Woods
Vice President Jim Landers
Secretary Shirley Anderson
Treasurer Nita Culp
Web Master Ken Fuchs

2017 Show Committees

Show Co-Chairs..... Jim Landers 254-773-5017
Karen Woods 254-217-1750
FacilitiesJoan Ervin
Staging & Properties.....Jim Landers
Secretary & AwardsNita Culp
Entries & Placement: Horticulture..... Karen Woods
Entries & Placement: Artistic Design.....Ken Fuchs
Entries & Placement: Photography.....Nita Culp
Recorder: Horticulture & Artistic Design..... Jaime Hadley
Recorder: Photography.....Jaime Hadley
Clerks: Horticulture..... Karen Woods
Assistant.....David Krauskopf
Assistant.....B.J. Wheeler
Clerks: Artistic DesignFrank Wheeler
Clerks: Photography.....Susan Krauskopf
Judges: Horticulture & Artistic Design.....Jim Landers
Judges: PhotographyKaren Woods
Hospitality.....B.J. Wheeler
Publicity.....Nelwyn Persky
Set Up & Clean Up..... All Members

Show Schedule General Rules

1. This accredited show is being held and judged under the rules and regulations of the American Iris Society as set forth in the *Handbook for Judges and Show Officials, 7th Edition, 2007*, and subsequent rules and regulations approved by The American Iris Society Board of Directors. These rules and regulations may not be violated.
2. Accredited judges of the American Iris Society will judge all entries in Divisions I, II, III, IV (as appropriate), and V. Members of Central Texas Photography Club will judge all entries in Division VII and IV (as appropriate). Exhibits will be disqualified and not judged if subjects are not appropriate, criteria and/or rules not followed. At judge(s)' discretion, any award may be withheld. Judge(s)' decisions are final.
3. Admission to AIS approved shows is open to the public from 1:00 to 3:00 p.m. at no charge.
4. Only authorized persons will be allowed in show area during judging.
5. The Entries and Placement Committee(s) may divide, sub-divide, combine or create sections as necessary. If an entry is able to enter more than one section, the appropriate Entries and Placement Committee Chair will determine the proper section so all such entries are entered in the same manner. (i.e. Historic has priority over Space Age, which has priority over TB.)
6. Judge(s) and their immediate family members, are not permitted to exhibit in same division(s) being judged.
7. All dimensions (inches and feet) listed are approximate, as specific dimensions vary by manufacturer.
8. All exhibits will be placed by Entry & Placement Committee's Clerks. Once placed, no further grooming or adjustments are allowed by exhibitor.
9. The Show Committee will exercise all possible care and will endeavor to protect all exhibits but, Belton Iris Society, judge(s), or venue(s) are not responsible for loss or damage to exhibits.
10. All exhibits require an entry tag, provided by Show Committee. Exhibitor will complete, in ink, listing: exhibitor's name(s), name of variety (number or name in Seedling Division), division number, section number, group/class number(s) in proper locations on tag, as appropriate. Incomplete or incorrect tags will be disqualified from competition. Please reference Figure 1.

Division I: Horticulture

Special Rules: Division I, Horticulture

1. Entries will be accepted between 7:00 and 10:00 a.m. on Saturday, April 15, 2017 and should be removed after 3:00 p.m. same day.
2. Judging will begin after 10:00, at the judge(s) discretion.
3. The horticulture and seedling divisions are open to any grower.
4. This is a VARIETY/CULTIVAR show, staged according to type and in alphabetical order within the various sections and groups. Each variety constitutes a separate group and must be correctly named. No unnamed variety may be exhibited, except seedlings which may be entered under number.
5. Exhibitor may enter only one stalk of a variety (named iris), in single specimen and seedling sections (does not include collections), but may enter any number of varieties as desired.
6. Entries must have been grown, transported and entered, in person, by the exhibitor whose name appears on the entry tag. Members of a single family garden may exhibit from the same garden, as an exhibitor unit, provided they work in the garden OR family members may enter as separate exhibitors from the same garden, but never both at the same show.

7. To constitute a section, a minimum of five cultivars must be entered by a minimum of three exhibitors.
8. Containers will be green bottles furnished by the exhibitor.
9. An exhibitor may enter a seedling originated by another person but the hybridizer's name and the seedling name or number must appear on the entry card.
10. Exhibits hybridized in Texas should have a Capital "T" placed in the upper left hand corner of both sections of the Entry Tag.
11. Historic irises should have the year of introduction in the upper right hand corner of both sections of the Entry Tag.
12. Unnamed stalks (except seedlings), potted exhibits or labeled irises grown by another person are not eligible for AIS ribbons and awards, but may be displayed if labeled "FOR DISPLAY ONLY".
13. **English Boxes:**
 - a. An English Box will consist of individual flowers of the same classification of irises (TB, IB, etc.). Flowers may be all different cultivars (named iris) or all the same variety.
 - b. A standard English Box consists of six flowers. Refer to Figure 2.
 - c. A mini English Box consists of three flowers. Refer to Figure 3.
 - d. A 3" x 5" card/paper with the correct iris names in correct positions must be prepared by exhibitor. It will be placed in front of exhibit with entry tag by Show Clerk.
 - e. Exhibitor shall furnish: 24" x 18" x 2" and/or 8" round green or neutral color Styrofoam (may be covered/painted green) and water tubes (picks).
 - f. Exhibitor may enter only one exhibit per group, but may enter as many groups as desired.
 - g. Judging will be determined by the following scale of points:

1.	Overall Beauty.....	15
2.	Color and Pattern Combination.....	20
3.	Cultural Perfection.....	45
4.	Condition and Grooming.....	<u>20</u>
		100

Sections: Division I, Horticulture

SECTION A. Tall Bearded Iris	Group 2. Arilbred
SECTION B. Miniature Dwarf Bearded	Group 3. Arilmed
SECTION C. Standard Dwarf Bearded	SECTION M. Bulbous Iris
SECTION D. Intermediate Bearded	SECTION N. Any Other Iris
SECTION E. Border Bearded	SECTION O. Collections
SECTION F. Miniature Tall Bearded	Group 1. 3 stalks/one variety
SECTION G. Space Agers	Group 2. 3 stalks/all different
SECTION H. Novelty Bearded	Group 3. 5 stalks/one variety
SECTION I. Louisianas	Group 4. 5 stalks/all different
SECTION J. Spuria	SECTION P. English Box
SECTION K. Historic Iris (introduced prior to 1988)	Group 1. Standard English Box
SECTION L. Aril & Arilbred	Group 2. Mini English Box
Group 1. Aril	

Awards: Division I, Horticulture (American Iris Society and Belton Iris Society)

1. **Best Specimen of Show** (Also known as Queen of Show): One AIS rosette (large purple) & certificate may be awarded.

The following exhibits are NOT eligible for Best Specimen of Show:

- Artistic and Educational entries
- English Box or individual blossom entries
- Potted iris entries
- Bulbous iris entries
- Seedlings, including named and registered but non-introduced irises
- Irises in a Section where another iris was awarded the Best of Section rosette
- Misclassified or mis-named iris entries
- Collection entries
- “For Display Only” entries

2. **Special Awards for Colors** (Queen’s Table): AIS rosette (small purple) may be awarded based upon the following colors:

Amoena	Plicata	Blue	Purple
Bicolor	Rimmed	Brown	Red
Bitone	Self	Gray	Tan
Blend	Striped	Green	White
Luminata	Variegata	Orange	Yellow
Neglecta	Black	Pink	Multi Color

3. **Special Awards for Sections** (Queen’s Table): AIS rosette (small purple) may be awarded to the following:

SECTION A. Tall Bearded Iris	SECTION I. Louisiana
SECTION B. Miniature Dwarf Bearded	SECTION J. Spuria
SECTION C. Standard Dwarf Bearded	SECTION K. Historic (introduced prior to 1988)
SECTION D. Intermediate Bearded	SECTION L. Aril & Arilbred
SECTION E. Border Bearded	SECTION M. Bulbous Iris
SECTION F. Miniature Tall Bearded	SECTION N. Any Other Iris
SECTION G. Space Agers	SECTION O. Colletions
SECTION H. Novelty Bearded	SECTION P. English Box

NOTE: To constitute a section, a minimum of five cultivars must be entered by a minimum of three exhibitors.

4. **Special Award for Texas Hybridized** (Queen’s Table): AIS rosette (small purple) may be awarded.
5. **Ribbons:** Only one first-place ribbon (blue), one second-place ribbon (red), and one third-place ribbon (white) may be awarded to each cultivar in any given section (except collections). As many honorable mention ribbons (pink) as quality merits may be awarded. Each cultivar may receive only one ribbon.
6. **Horticulture Sweepstakes** (most blue ribbons): AIS Silver Medal and Certificate.
7. **Horticultural Sweepstakes Runner-up** (second most blue ribbons): AIS Bronze Medal and Certificate.

NOTE: To award bronze and/or silver medals, the show must be accredited, show at least twenty iris cultivars, that have been properly registered and introduced and which are exhibited as single cut specimen stalks, and have a minimum of five exhibitors. Youth division numbers are reduced to ten cultivars and a minimum of two exhibitors.

NOTE: In tallying horticulture sweepstakes, do NOT include ribbons for:

- Division I, Horticulture’s single blossom classes
- Division II, Seedlings

Division II: Seedlings

Special Rules: Division II, Seedlings

1. Any unIntroduced iris of any type. Seedlings must be entered under seedling number or registered name and must be made in the name of the owner or originator of the clone.
2. Entries use same Sections and Groups as in Division I: Horticulture, Sections A-J and L.

NOTE: Judging of seedlings is distinctly different from judging of introduced varieties. Grooming and condition of the iris seedling (which are skills shown by the exhibitor) are not considered. Evaluation of the quality of the iris stalk and flower, and distinctiveness are among the criteria used by judges in this division.

Awards: Division II, Seedlings

1. **Best Seedling of Show:** One AIS rosette (large purple) & Exhibition Certificate may be awarded.
2. **Exhibition Certificate** will automatically be awarded to any seedling receiving five or more votes from fully accredited AIS judges attending the show. (Not awarded at Show.)
3. **Ribbons:** Only blue ribbons are awarded to seedlings, when merited.

Division III: Artistic Design

Special Rules: Division III, Artistic Design

1. Entries will be accepted between 7:00 and 10:00 a.m. on Saturday, April 15, 2017 and should be removed after 3:00 p.m. same day.
2. Judging will begin after 10:00, at the judge(s) discretion.
3. Artistic Design is open to anyone.
4. Entries must have been designed, transported and entered, in person, by the exhibitor whose name appears on the entry tag. (Only one name on entry tag.)
5. Exhibitor may enter only one exhibit per section, but may enter as many sections as desired.
6. To constitute a section, a minimum of three exhibits must be entered by a minimum of three exhibitors.
7. Display boards (niches), which are optional, have open dimensions of 3' tall and 4' wide and may be provided by the exhibitor or Belton Iris Society (if available when requested). All other materials to complete the exhibit will be provided by the exhibitor.
8. The entire display board, if used, shall be draped or covered by the exhibitor. (Use of pre-colored display board is acceptable.)
9. The design must be created by the exhibitor, but plant material used in the design does NOT have to have been grown by the exhibitor.
10. One or more iris bloom(s) must be used in each exhibit and must be the dominant flower(s) and point of interest. Use of iris foliage is the exhibitor's choice.
11. Other flowers, foliages, dried plant materials, accessories, bases, and weathered woods are permitted in all sections. Fresh plant material may not be treated, but dried plant material may be treated.
12. No artificial flowers, foliages, fruits, or vegetables are permitted.
13. The use of any part(s) of plants on the Texas State Conservation List is strictly prohibited.
14. The use of the American, Texas, or any international flag is prohibited. Flags are NOT accessories. The use of colors or bunting is permitted.

15. Accessories are permitted in all sections.
16. No person shall touch, feel, adjust, or move any part of an exhibit, except the exhibitor. If something needs adjustment/correction, notify the exhibitor.
17. It is recommended that exhibits be made at home so only minor adjustments/corrections are required at the time of placement.

Sections: Division III, Artistic Design

- SECTION A. Easter Irises
- SECTION B. Irises My Love

Awards: Division III, Artistic Design

1. **Best Artistic Design of Show:** One AIS rosette (small purple) may be awarded.
2. **Ribbons:** Only one first-place ribbon (blue), one second-place ribbon (red), and one third-place ribbon (white) may be awarded in each section. As many honorable mention ribbons (pink) as quality merits may be awarded. Each exhibit may receive only one ribbon.

Judging: Division III, Artistic Design

Judging will be determined by the following scale of points:

1.	Conformance to Schedule Requirements	10
2.	Design Principles.....	35
	a. Balance.....	5
	b. Proportion.....	5
	c. Scale.....	5
	d. Rhythm.....	5
	e. Dominance.....	5
	f. Contrast.....	5
	g. Unity.....	5
3.	Color Harmony.....	20
4.	Artistic Expression/Elements of Design	20
5.	Distinction.....	15
		100

Division IV: Youth Horticulture

1. Same Special Rules, Sections, Awards, and Judging as in Division I: Horticulture, Division II: Seedlings, Division III: Artistic Design, Division V: Educational Exhibits, and Division VII: Photography.
2. Youth exhibitors (persons under 19 years of age) may enter exhibits in Youth divisions OR Adult divisions but not both.

Division V: Educational Exhibits

Special Rules: Division V, Educational Exhibits

1. Entries will be accepted between 7:00 and 10:00 a.m. on Saturday, April 15, 2017 and should be removed after 3:00 p.m. same day.
2. Judging will begin after 10:00, at the judge(s) discretion.
3. Educational exhibits are open to anyone.

4. Foam Boards with dimensions of 20" x 30" and display boards (niches) with open dimensions of 3' tall and 4' wide are authorized. Additional sizes may be authorized by Show Committee, if requested and approved in advance of Show.
5. Works Referenced (citation) via the Publication Manual of the American Psychological Association (APA) are to be included in exhibit, if applicable.
6. Written permission to use previously published text, tables, or figures must be secured to the back of exhibit(s), if applicable. (Emails are acceptable.)
7. All materials for exhibits will be provided by exhibitor.
8. Reservations are required by Show Committee to ensure available space.

Sections: Division V, Educational Exhibits

SECTION A. Iris Culture

SECTION B. Planting/Growing Irises

Awards: Division V, Educational Exhibits

1. **Special Award, Best Educational Exhibit of Show:** One AIS rosette (small purple) may be awarded.
2. **Ribbons:** Only one first-place ribbon (blue), one second-place ribbon (red), and one third-place ribbon (white) may be awarded in each section. As many honorable mention ribbons (pink) as quality merits may be awarded. Each exhibit may receive only one ribbon.
3. **Bronze Medal Certificate:** May be awarded to the exhibitor of an educational exhibit found to be of outstanding merit by the judge(s).

Division VI: Commercial Exhibits

1. The Show Committee will determine if an exhibitor is to be given commercial status.
2. Reservations are required by Show Committee to ensure available space.
3. No awards are given in Division VI: Commercial Exhibits.

Division VII: Photography

Special Rules: Division VII, Photography

1. Entries will be accepted between 7:00 and 10:00 a.m. on Saturday, April 15, 2017 and should be removed after 3:00 p.m. same day.
2. Judging will begin after 10:00, at the judge(s) discretion.
3. Photography is open to anyone.
4. Exhibits (matted photographs) must have been photographed, transported and entered, in person, by exhibitor whose name appears on entry tag. (Only one name on entry tag.)
5. Entry tag will be placed in front of exhibit by Show Clerk.
6. Exhibitor may enter only one exhibit per section, but may enter as many sections as desired.
7. To constitute a section, a minimum of three exhibits must be entered by a minimum of three exhibitors.
8. Subjects are NOT required to be grown or owned by exhibitor.
9. There are no requirements as to when or where subject was photographed.
10. All exhibits must be in color, use an 8"x10" photograph format and be matted.
11. Picture frames and glass are not permitted.
12. Matt(s) will be provided by exhibitor and are exhibitor's choice of width, color, style, texture, and used to enhance subject.
13. Image modifications/manipulations:

- a. Modifications may be made to the image in the photo editing mode of cameras, apps (Pro Camera), or programs (Photoshop), as long as the modification is applied to the whole image and not just part of the image.
- b. Adding graphics, borders, text, clip art, computer generated images, and images from other photographs is NOT permitted.

Sections: Division VII, Photography

Section A. Single Iris

(Photograph of a single iris.)

Section B. Multitude Irises

(Photograph of more than one iris. Blooms may be on the same iris stalk or on multiple stalks.)

Awards: Division VII, Photography

1. **Special Award, Best Photograph of Show:** One AIS rosette (small purple) may be awarded.
2. **Ribbons:** Only one first-place ribbon (blue), one second-place ribbon (red), and one third-place ribbon (white) may be awarded in each section. Each exhibit may receive only one ribbon.

Judging: Division VII, Photography

1. Quantity of judge(s) and selection of individual(s) for judges will be determined by Central Texas Camera Club.
2. Judging will be determined with the following having equal importance:
 - a. **Impact:** It makes you think, "Wow!" this is a great photo (for a high score). Or, it may make you think, "Baw!" this is not a good photo (for a low score).
 - b. **Composition:** A photograph that has artistic presentation. It has a focal point, great color, and no distractions.
 - c. **Technique:** Proper exposure (not too light or too dark), good focus, and proper depth of field.

Figure 1. Sample Entry Tag

"T" is for Texas hybridizer. Always a capital letter "T". Add to the upper left hand corner of both sections. Examples: Tom Burseen = T Hooker Nichols = T

Variety. is the name of the iris or number if it is a seedling. *Either a name or number, but not both.* Examples: iris name = Cairo Love Song seedling number = 7526 artistic design = Section name

Exhibitor is the person who grows, transports, and enters the entry. *May be an individual or family.*

Address is the location of the garden or where exhibitor lives. *Optional.*

Entry No. is the number assigned to exhibitor by the Show clerk. *Same number used for all entries.* Example: assigned number nine = 9

Division is the division number listed in the Show schedule. *Always a Roman numeral.* Examples: Horticulture, English Box = I Artistic Design = III Photography = VII

Section is the section letter listed in the Show Schedule. *Always a capital letter.* Examples: TB = A AB = L photo for Section B = B

Group is the subsection of the Section. *Always a number. Not every entry will have a Group.* Example: TB = none Arilbred = 2

Historic, add year of introduction to the upper right hand corner of both sections.

Figure 2. Standard English Box

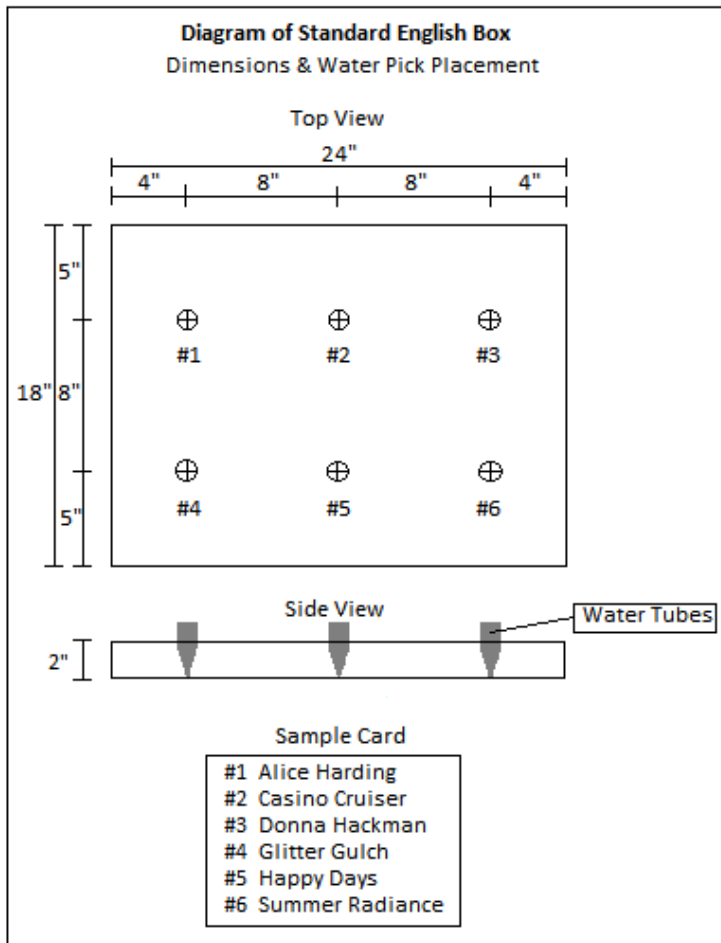
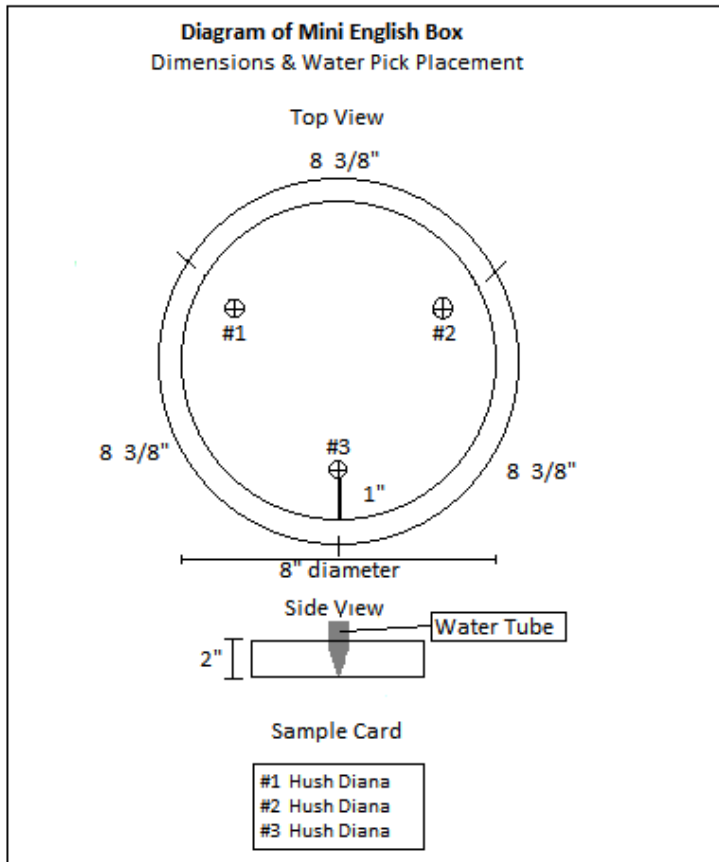

Figure3. Mini English Box



Good Luck